

12. Electromagnetic Induction

Please remember to photocopy 4 pages onto one sheet by going A3→A4 and using back to back on the photocopier

Contents

Electromagnetic induction: ordinary level questions	2
Electromagnetic induction and Faraday's law: higher level questions.....	4
Lenz law demonstrations.....	6
Self-induction.....	7
Transformers: ordinary level questions	9
Transformers: higher level questions	10
Solutions to all higher level exam questions	11

Electromagnetic induction: ordinary level questions

2015 Question 12 (d) [Ordinary Level]

A solenoid (long coil of wire) is connected to a battery as shown.

- Copy the diagram into your answer book and draw the magnetic field in and around the solenoid.
- Explain the term *electromagnetic induction*.
- A magnet and a solenoid can together be used to produce electricity. Describe, with the aid of a diagram, how this can be done.

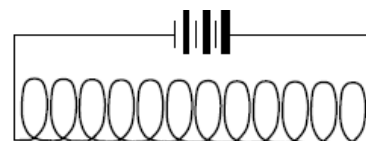

2014 Question 9 [Ordinary Level]

- A magnetic field exists around a current-carrying conductor. What is a magnetic field?
- How does a compass indicate the direction of a magnetic field?
- Describe an experiment to show that there is a magnetic field around a current-carrying conductor and sketch the field lines around the conductor.
- Sketch the magnetic field around a bar magnet.
- A coil of wire is connected as shown in the diagram to a galvanometer. A bar magnet is placed near the coil. What is observed when the magnet is moved towards the coil?
- What is observed when the magnet is stationary?
- Explain these observations.
- How would increasing the speed of movement of the magnet alter the observations?

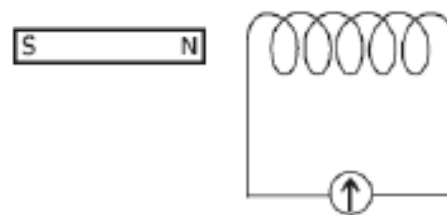

2010 Question 11 [Ordinary Level]

Read this passage and answer the questions below.

In 1819 the Danish physicist Hans Christian Oersted discovered that an electric current flowing through a wire deflected a compass needle.

A year later the Frenchman François Arago found that a wire carrying an electric current acted as a magnet and could attract iron filings. Soon his compatriot André-Marie Ampère demonstrated that two parallel wires were attracted towards one another if each had a current flowing through it in the same direction. However, the wires repelled each other if the currents flowed in the opposite directions.

Intrigued by the fact that a flow of electricity could create magnetism, the great British experimentalist Michael Faraday decided to see if he could generate electricity using magnetism. He pushed a bar magnet in and out of a coil of wire and found an electric current being generated. The current stopped whenever the magnet was motionless within the coil.

- Who discovered that an electric current can deflect a compass needle?
- What did Arago discover?
- What happens when currents flow in the same direction in two parallel wires?
- How could two parallel wires be made to repel each other?
- Draw a sketch of the apparatus Michael Faraday used to generate electricity.
- What name is given to the generation of electricity discovered by Michael Faraday?
- What energy conversions take place in Faraday's experiment?
- How does Faraday's experiment show that a changing magnetic field is required to generate electricity?

2011 Question 9 (a) [Ordinary Level]

State Faraday's law of electromagnetic induction.

A coil of wire is connected to a sensitive meter, as shown in the diagram.

- (i) What is observed on the meter when the magnet is moved towards the coil?
- (ii) What is observed on the meter when the magnet is stationary in the coil?
- (iii) Explain these observations.
- (iv) How would changing the speed of the magnet affect the observations?

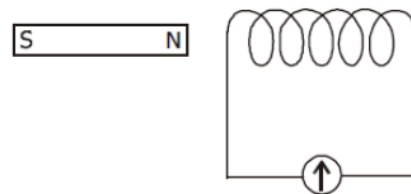

2005 Question 9 [Ordinary Level]

- (i) What is a magnetic field?
- (ii) Draw a sketch of the magnetic field around a bar magnet.
- (iii) Describe an experiment to show that a current carrying conductor in a magnetic field experiences a force.
- (iv) List two factors that affect the size of the force on the conductor.
- (v) A coil of wire is connected to a sensitive galvanometer as shown in the diagram. What is observed when the magnet is moved towards the coil?
- (vi) Explain why this occurs.
- (vii) Describe what happens when the speed of the magnet is increased.
- (viii) Give one application of this effect.

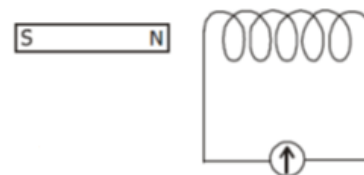

2008 Question 12 (d) [Ordinary Level]

- (i) What is electromagnetic induction?
- (ii) A magnet and a coil can be used to produce electricity.
- (iii) How would you demonstrate this?
- (iv) The electricity produced is a.c. What is meant by a.c.?

2018 Question 12 (d) [Ordinary Level]

- (i) What is electromagnetic induction?
- (ii) Explain how you would use a magnet and a coil, as shown above, to produce electricity.
- (iii) How would you know that electricity is being produced?
- (iv) How could you increase the magnitude of the electricity produced?
- (v) The apparatus in the diagram can be used to produce a.c. electricity. What is meant by a.c.?

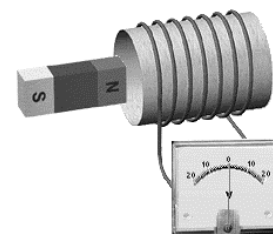

Electromagnetic induction and Faraday's law: higher level questions

2006 Question 11 [Higher Level]

Read the following passage and answer the accompanying questions.

The growth of rock music in the 1960s was accompanied by a switch from acoustic guitars to electric guitars. The operation of each of these guitars is radically different.

The frequency of oscillation of the strings in both guitars can be adjusted by changing their tension. In the acoustic guitar the sound depends on the resonance produced in the hollow body of the instrument by the vibrations of the string. The electric guitar is a solid instrument and resonance does not occur.

Small bar magnets are placed under the steel strings of an electric guitar, as shown. Each magnet is placed inside a coil and it magnetises the steel guitar string immediately above it. When the string vibrates the magnetic flux cutting the coil changes, an emf is induced causing a varying current to flow in the coil. The signal is amplified and sent to a set of speakers.

Jimi Hendrix refined the electric guitar as an electronic instrument. He showed that further control over the music could be achieved by having coils of different turns.

(Adapted from Europhysics News (2001) Vol. 32 No. 4)

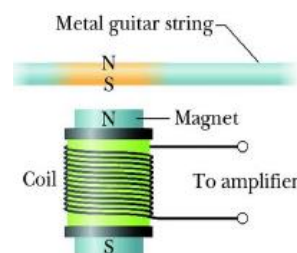

- How does resonance occur in an acoustic guitar?
- What is the relationship between frequency and tension for a stretched string?
- A stretched string of length 80 cm has a fundamental frequency of vibration of 400 Hz.
What is the speed of the sound wave in the stretched string?
- Why must the strings in the electric guitar be made of steel?
- Define magnetic flux.
- Why does the current produced in a coil of the electric guitar vary?
- What is the effect on the sound produced when the number of turns in a coil is increased?
- A coil has 5000 turns. What is the emf induced in the coil when the magnetic flux cutting the coil changes by $8 \times 10^{-4} \text{ Wb}$ in 0.1 s?

2005 Question 12 (b) [Higher Level]

- Define magnetic flux.
- State Faraday's law of electromagnetic induction.
- A square coil of side 5 cm lies perpendicular to a magnetic field of flux density 4.0 T.
The coil consists of 200 turns of wire.
What is the magnetic flux cutting the coil?
- The coil is rotated through an angle of 90° in 0.2 seconds.
Calculate the magnitude of the average e.m.f. induced in the coil while it is being rotated.

2018 Question 9 [Higher Level]

James Clerk Maxwell, a Scottish physicist, is considered the greatest theoretical physicist of the nineteenth century.

Early in his career he investigated colour and light.

Maxwell created a colour triangle to illustrate the relationship between primary and secondary colours of light.

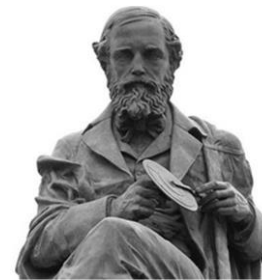

Using his triangle or otherwise

- (i) list the primary colours of light,
- (ii) Name a pair of complementary colours of light.

Maxwell later published equations that describe how electric charges and currents create electric and magnetic fields. He also described how a changing electric field can generate a changing magnetic field.

- (i) What is a magnetic field?
- (ii) Draw labelled diagrams to show the magnetic field about a long straight current-carrying wire.
- (iii) Draw labelled diagrams to show the magnetic field about a current-carrying solenoid.

One of Maxwell's equations is equivalent to Faraday's law of electromagnetic induction.

- (iv) State Faraday's law of electromagnetic induction.
- (v) Describe an experiment to demonstrate this law.
- (vi) A square coil of 40 turns with a side of length 20 cm is perpendicular to a magnetic field of flux density 50 mT.

What is the average emf induced in the coil when it is rotated through 90° in $\frac{1}{4}$ of a second?

(The axis of rotation connects the midpoints of opposite sides of the square, as shown.)



Maxwell also showed that visible light is an electromagnetic wave and that some types of invisible waves belong in the electromagnetic spectrum too.

- (vii) The eye is the sense organ that detects light. Where in the eye is light detected?
- (viii) List two invisible parts of the electromagnetic spectrum that have a shorter wavelength than visible light.

Lenz law demonstrations

2014 Question 12 (d) [Higher Level]

- (i) State Faraday's law of electromagnetic induction.
- (ii) Describe an experiment to demonstrate Faraday's law.
- (iii) A hollow copper pipe and a hollow glass pipe, with identical dimensions, were arranged as shown in the diagram.
- A student measured the time it took a strong magnet to fall through each cylinder. It took much longer for the magnet to fall through the copper pipe. Explain why.

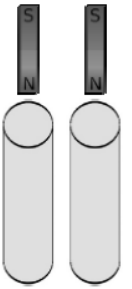

2008 Question 8 [Higher Level]

- (i) What is electromagnetic induction?
- (ii) State the laws of electromagnetic induction.
- (iii) A bar magnet is attached to a string and allowed to swing as shown in the diagram. A copper sheet is then placed underneath the magnet.
- Explain why the amplitude of the swings decreases rapidly.
- (iv) What is the main energy conversion that takes place as the magnet slows down?
- (v) A metal loop of wire in the shape of a square of side 5 cm enters a magnetic field of flux density 8 T.
- The loop is perpendicular to the field and is travelling at a speed of 5 m s^{-1} . How long does it take the loop to completely enter the field?
- (vi) What is the magnetic flux cutting the loop when it is completely in the magnetic field?
- (vii) What is the average emf induced in the loop as it enters the magnetic field?

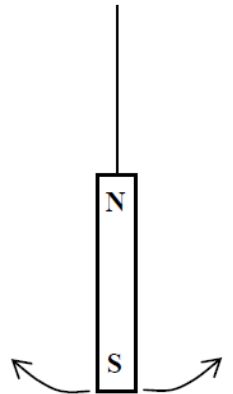

2004 Question 12 (c) [Higher Level]

- (i) What is electromagnetic induction?
- (ii) Describe an experiment to demonstrate electromagnetic induction.
- (iii) A light aluminium ring is suspended from a long thread as shown in the diagram.
- When a strong magnet is moved away from it, the ring follows the magnet. Explain why.
- (iv) What would happen if the magnet were moved towards the ring?

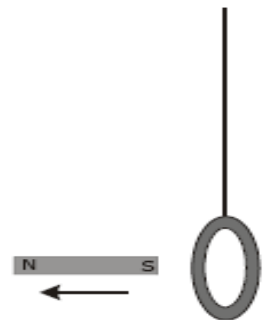

2003 Question 12 (d) [Higher Level]

- (i) State the laws of electromagnetic induction.
- (ii) A small magnet is attached to a spring as shown in the diagram.
- The magnet is set oscillating up and down. Describe the current flowing in the circuit.
- (iii) If the switch at A is open, the magnet will take longer to come to rest. Explain why.

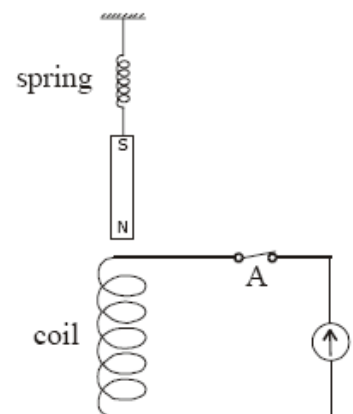

Self-induction

2007 Question 12 (c) [Higher Level]

- State Faraday's law of electromagnetic induction.
- Describe an experiment to demonstrate Faraday's law.
- A resistor is connected in series with an ammeter and an ac power supply. A current flows in the circuit. The resistor is then replaced with a coil. The resistance of the circuit does not change. What is the effect on the current flowing in the circuit? Justify your answer.

2002 Question 12 (c) [Higher Level]

- What is meant by electromagnetic induction?
- State Lenz's law of electromagnetic induction.
- In an experiment, a coil was connected in series with an ammeter and an a.c. power supply as shown in the diagram. Explain why the current was reduced when an iron core was inserted in the coil.
- Give an application of the principle shown by this experiment.

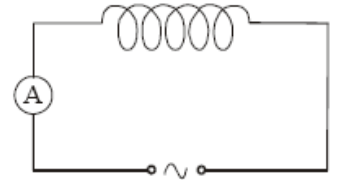

2016 Question 10 [Higher Level]

- State Faraday's law of electromagnetic induction.
- Describe an experiment to demonstrate this law.
- Derive an expression for the effective resistance of two resistors in parallel.

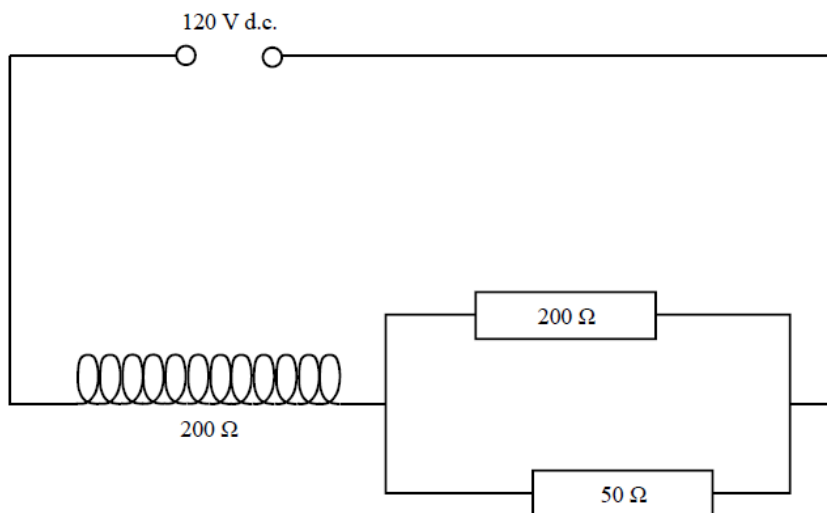

A coil consists of 150 turns of wire and has a total resistance of 200Ω . It is connected in series with a 120 V d.c. power supply and a parallel combination of a 200Ω and a 50Ω resistor, as shown.

- Calculate the current in the coil
- Calculate the current in the 50Ω resistor.

The d.c. supply is then replaced with an a.c. supply.

It takes 3 ms for the magnetic flux cutting the coil to increase by 4.5×10^{-4} Wb.

The average voltage of the a.c. supply during this time period is 120 V.

- Calculate the average emf induced in the coil during the 3 ms time period
- Calculate the average current in the coil during this period.

2017 Question 8 {last 2 parts} [Higher Level]

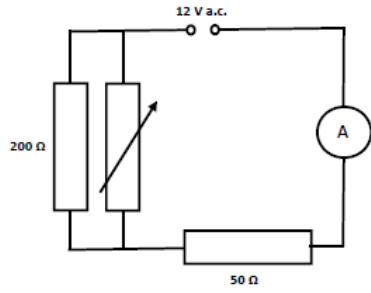

The variable resistor is then removed.

In further investigations, the 50 Ω resistor was then replaced with (a) a coil of resistance 50 Ω and (b) a diode, as shown.

(viii) In each of the investigations, what effect did the replacement have on the current flowing?

(ix) Justify your answer in each case.

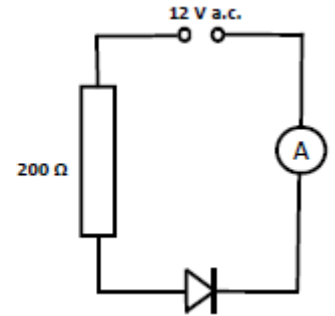
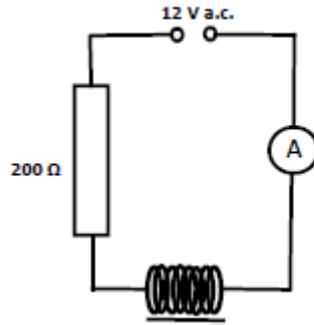

Transformers: ordinary level questions

2002 Question 9 [Ordinary Level]

- (i) What is electromagnetic induction?
- (ii) Describe an experiment to demonstrate electromagnetic induction.
- (iii) The transformer is a device based on the principle of electromagnetic induction.

Name two devices that use transformers.

- (iv) Name the parts of the transformer labelled A, B and C in the diagram.
- (v) The mains electricity supply (230 V) is connected to A, which has 400 turns. C has 100 turns. What is the reading on the voltmeter?
- (vi) How is the part labelled B designed to make the transformer more efficient?
- (vii) The efficiency of a transformer is 90%. What does this mean?

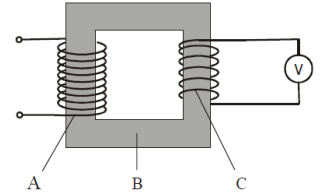

2004 Question 12 (c) [Ordinary Level]

- (i) A transformer is a device based on the principle of electromagnetic induction.
- (ii) What is electromagnetic induction?
- (iii) Name another device that is based on electromagnetic induction.
- (iv) Name the parts of the transformer labelled A, B and C in the diagram.
- (v) Part A has 400 turns of wire and part B has 1200 turns. Part A is connected to a 230 V a.c. supply. What is the voltage across part B?

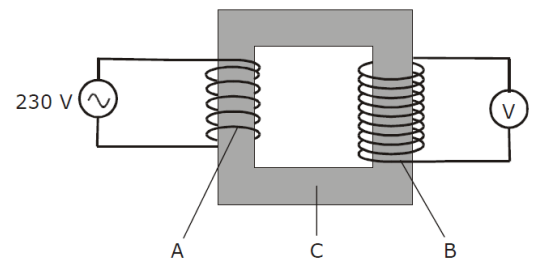

2007 Question 12 (d) [Ordinary Level]

The diagram shows a transformer.

- (i) What is electromagnetic induction?
- (ii) Name the parts labelled A and B.
- (iii) The input voltage is 230 V. Part B has 4600 turns and part C has 120 turns.

Calculate the output voltage.

- (iv) Name a device that uses a transformer.

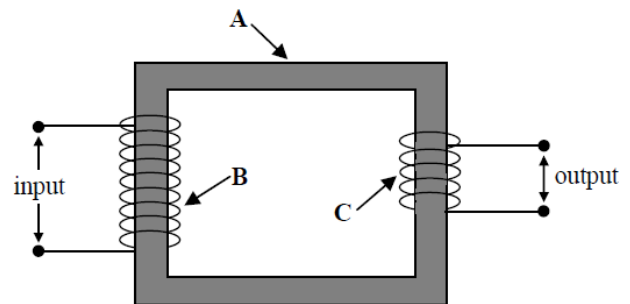

2011 Question 9 (b) [Ordinary Level]

Transformers are used to step up or step down a.c. voltages.

- (i) What is meant by a.c.?
- (ii) Draw a labelled diagram showing the structure of a transformer.
- (iii) The input coil of a transformer has 200 turns of wire and is connected to a 230 V a.c. supply. What is the voltage across the output coil, when it has 600 turns?

2013 Question 11 [Ordinary Level]

- (i) Why are high voltages used to transmit power over the national grid?
- (ii) Why is the power supplied to domestic customers at lower voltages?
- (iii) Name two renewable and two non-renewable energy sources used to generate electricity.
- (iv) The national grid uses alternating current (a.c.) rather than direct current (d.c.). What is the difference between them?
- (v) Name the device used to convert high voltages to lower voltages.
- (vi) Give the principle of operation of the device named in part (v).
- (vii) Name the unit of electrical energy that is used in the delivery of electricity to homes and businesses.

Transformers: higher level questions

2013 Question 8 (a) [Higher Level]

- (i) The diagram shows a circuit used in a charger for a mobile phone.
Name the parts labelled **F**, **G** and **H**.
- (ii) Describe the function of **G** in this circuit.
- (iii) Sketch graphs to show how voltage varies with time for the input voltage and the output voltage, V_{XY} .
- (iv) The photograph shows the device **H** used in the circuit.
Use the data printed on the device to calculate the maximum energy that it can store.

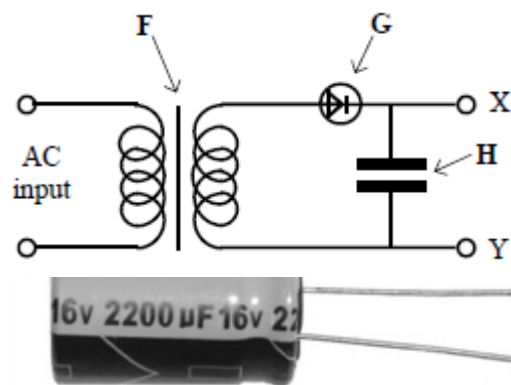

2015 Question 11 [Higher Level]

Read the following passage and answer the accompanying questions.

In the years since his death, Nikola Tesla (1856–1943) has enjoyed a curious legacy. On the one hand he is acknowledged for his contributions to alternating current and in 1960 “tesla” was adopted as the name of the unit of measure for magnetic flux density. On the other hand, thanks to the many colourful predictions he made about his inventions, Tesla has become a figure in popular culture.

Tesla was the champion of distributing electric power using alternating current rather than direct current.

The problem with using direct current for electric lighting is that there is no easy way to transfer power from one d.c. circuit to another. Because the generator and the light bulbs must then be part of the same circuit, safety requires that the entire circuit uses low voltage and large current. Alternating current makes it easy to transfer power from one circuit to another, by electromagnetic induction in a device called a transformer.

The wires that carry the current a long distance are part of a high voltage, low current circuit and therefore waste little power.

As well as his work with alternating current, Tesla did pioneering work on the transmission of radio-waves and X-rays. In 1898 he demonstrated a radio-controlled boat.

The car manufacturing company, *Tesla Motors*, is also named in honour of Tesla. The *Tesla Roadster* uses an a.c. motor descended directly from Tesla’s original 1882 design.

It is the first production car to use lithium-ion cells and has a range of greater than 300 km.

(Adapted from *Tesla: Inventor of the Electrical Age*, W Bernard Carlson, Princeton University Press, 2013)

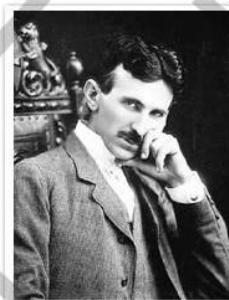

- (a) Define the tesla.
- (b) Sketch voltage-time graphs for (i) an a.c. supply and (ii) a d.c. supply.
- (c) Explain the term *electromagnetic induction*.
- (d) Why does a transformer not work with direct current?
- (e) Why is it inefficient to use low voltage when transmitting electricity?
- (f) The peak voltage of an a.c. supply is 321 V. Calculate the rms voltage.
- (g) Explain why it is necessary to use rms values when comparing a.c. and d.c. electricity.
- (h) Give one advantage and one disadvantage of electric cars.



Solutions to all higher level exam questions

2018 Question 9

(iii) **List the primary colours of light**

red, green, blue

(iv) **Name a pair of complementary colours of light.**

Blue & yellow, green & magenta, red & cyan

(v) **What is a magnetic field?**

A magnetic field is any region where magnetic forces are felt

(vi) **Draw labelled diagram to show the magnetic field about a long straight current-carrying wire.**

See diagram

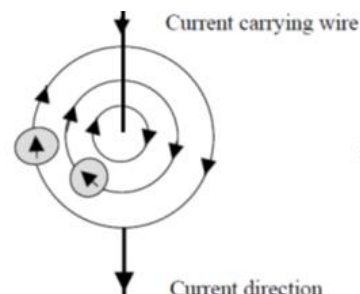

(vii) **Draw labelled diagrams to show the magnetic field about a current-carrying solenoid.**

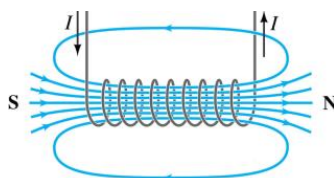

(viii) **State Faraday's law of electromagnetic induction.**

Faraday's law states that the size of the induced emf is proportional to the rate of change of magnetic flux.

(ix) **Describe an experiment to demonstrate this law.**

1. Move the magnet in and out of the coil slowly and note a slight deflection.
2. Move the magnet quickly and note a greater deflection.

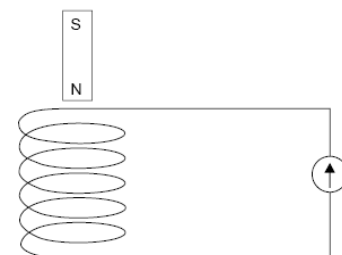

(x) **What is the average emf induced in the coil when it is rotated through 90° in 1/4 of a second?**

(The axis of rotation connects the midpoints of opposite sides of the square, as shown.)

$$\Phi = BA = (50 \times 10^{-3})(0.2)^2 = 2 \times 10^{-3} \text{ webers}$$

$$\text{Induced emf} = (N)[(\text{final flux} - \text{initial flux})/(\text{time taken})]$$

$$E = (40)[(2 \times 10^{-3} - 0)/0.25] \qquad E = 0.32 \text{ V}$$



(xi) **The eye is the sense organ that detects light. Where in the eye is light detected?**

The retina

(xii) **List two invisible parts of the electromagnetic spectrum that have a shorter wavelength than visible light.**

Ultraviolet, X-rays, gamma rays

2017 Question 8 {last 2 parts} [Higher Level]

(viii) **In each of the investigations, what effect did the replacement have on the current flowing?**

(ix) **Justify your answer in each case.**

When the resistor was replaced with a coil an emf was induced in the coil which opposed the driving emf so the overall voltage and current were reduced.

When the resistor was replaced with a diode the result was that the current could only flow in one direction – because that's what a diode does.

2016 Question 10

(i) State Faraday's law of electromagnetic induction.

Emf induced is proportional to the rate of change of magnetic flux
Or correct equation and notation

(ii) Describe an experiment to demonstrate this law.

Move the magnet in and out of the coil slowly and note a slight deflection in the galvanometer.
Move the magnet quickly and note a greater deflection.

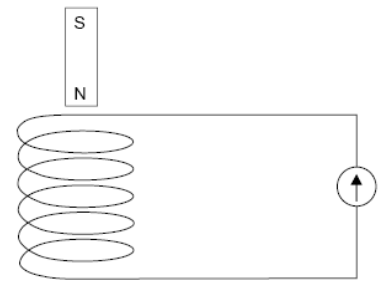

(iii) Derive an expression for the effective resistance of two resistors in parallel.

For currents in parallel: $I_{Total} = I_1 + I_2$

But $I = \frac{V}{R}$ (Ohm's Law)

$$\Rightarrow \frac{V}{R_T} = \frac{V}{R_1} + \frac{V}{R_2}$$

We can now cancel the V's because the voltage is the same for resistors in parallel

$$\Rightarrow \frac{1}{R_T} = \frac{1}{R_1} + \frac{1}{R_2}$$

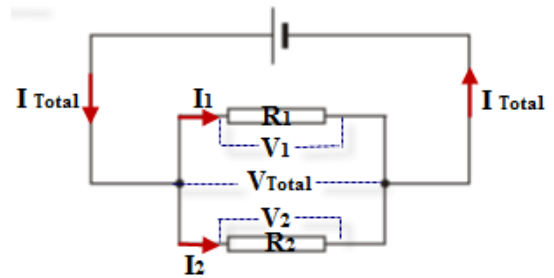

(iv) Calculate the current in the coil

R_T for resistors in parallel:

$$\frac{1}{R_T} = \frac{1}{200} + \frac{1}{50} \quad \frac{1}{R_T} = \frac{1}{40} \quad R_T \text{ for resistors in parallel} = 40 \Omega$$

$$R_{circuit} = 40 + 200 = 240 \Omega \quad V_{Total} = I_{Total} R_{Total} \quad I = \frac{V}{R} = \frac{120}{240} = 0.5 \text{ A}$$

(v) Calculate the current in the 50 Ω resistor.

Voltage across 200 ohm resistor = $IR = (0.5)(200) = 100 \text{ V}$

So voltage across parallel resistors must be $(220 - 100) = 120 \text{ V}$

To calculate the current in the 50 Ω resistor; $R = 50 \Omega$, $V = 120 \text{ V}$, $I = \frac{V}{R} = \frac{120}{50} = 2.4 \text{ A}$

Alternative approach: $I_{50} = \frac{4}{5}(I_{Total}) = 0.4 \text{ A}$

(vi) Calculate the average emf induced in the coil during the 3 ms time period

$$E = d\Phi/dt$$

$$\text{Induced emf} = - (N) \left[\frac{\text{final flux} - \text{initial flux}}{\text{time taken}} \right] \quad \text{Induced emf} = - (150) \left[\frac{4.5 \times 10^{-4} - 0}{3 \times 10^{-3}} \right]$$

$$E = 22.5 \text{ V}$$

(vii) Calculate the average current in the coil during this period.

The effective voltage across the coil now corresponds to the initial voltage – the induced voltage.

$$E_{coil} = 120 \text{ V} - 22.5 \text{ V} = 97.5 \text{ V} \quad I_{Total} = \frac{V_{Total}}{R_{Total}} \quad I = \frac{97.5}{240} = 0.406 \text{ A}$$

Note that the symbols V and E are interchangeable here.

2015 Question 11

(i) **Define the tesla.**

A magnetic flux density of one Tesla corresponds to a current of 1 A flowing through a wire of length 1 m causing a force of 1 N.

(ii) **Sketch voltage-time graphs for (i) an a.c. supply and (ii) a d.c. supply.**

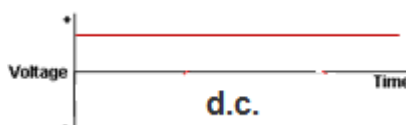
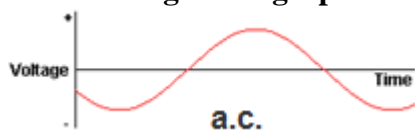

(iii) **Explain the**

term *electromagnetic induction*.

Electromagnetic Induction occurs when an emf is induced in a coil due to a changing magnetic flux.

(iv) **Why does a transformer not work with direct current?**

The current is not changing therefore the magnetic flux is not changing, therefore there is no induced emf.

(v) **Why is it inefficient to use low voltage when transmitting electricity?**

Low voltage means large currents which would result in more heat lost (than if the current were low).

(vi) **The peak voltage of an a.c. supply is 321 V. Calculate the rms voltage.**

$$V_{\text{rms}} = \frac{V_{\text{max}}}{\sqrt{2}} = \frac{321}{\sqrt{2}} = 227 \text{ V}$$

(vii) **Explain why it is necessary to use rms values when comparing a.c. and d.c. electricity.**

So as to make the power output equivalent between a.c. and d.c.

(viii) **Give one advantage and one disadvantage of electric cars.**

Advantage: e.g. fewer carbon emissions

Disadvantage: e.g. short range / expensive batteries

2014 Question 12 (d)

(i) **State Faraday's law of electromagnetic induction.**

The size of the induced emf is proportional to the rate of change of flux.

(ii) **Describe an experiment to demonstrate Faraday's law.**

- Move the magnet in and out of the coil slowly and note a slight deflection.
- Move the magnet quickly and note a greater deflection.

(iii) **Explain why.**

The falling magnet creates a changing magnetic flux in both tubes.

An emf is therefore induced in both tubes.

But current flows in only the copper tube because this is the only material that is a conductor.

This induced current generates a magnetic field which opposes the motion of the falling magnet.

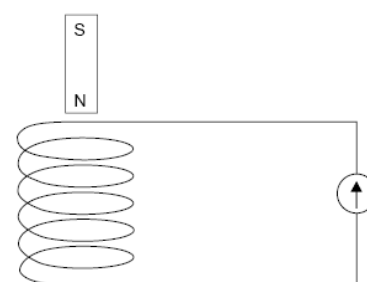

2013 Question 8

(a)

(i) Name the parts labelled F, G and H.

F: transformer / iron core

G: diode

H: capacitor

(ii) Describe the function of G in this circuit.

It acts as a rectifier: it converts a.c. to d.c.

(iii) Sketch graphs to show how voltage varies with time for the input voltage and the output voltage

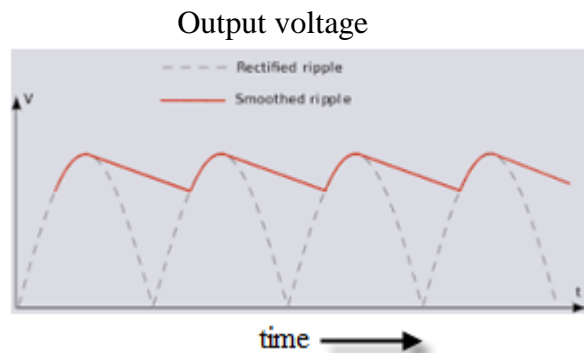
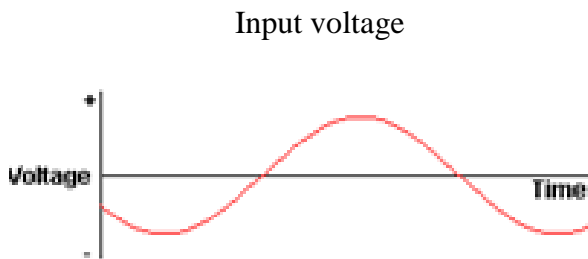

(iv) Use the data printed on the device to calculate the maximum energy that it can store.

$$E = \frac{1}{2}CV^2$$

$$E = (\frac{1}{2})(2200 \times 10^{-6})(16)^2$$

$$E = 0.2816 \text{ J}$$

(b)

(i) Explain why high voltage is used.

High voltage uses low current minimising heat loss

(ii) Calculate the resistance of the aluminium wire.

$$\rho = \frac{RA}{l} \quad R = \frac{\rho l}{A}$$

$$\text{Diameter} = 18 \text{ mm} \quad r = 9 \times 10^{-3} \text{ m}$$

$$A = \pi r^2 = \pi(9 \times 10^{-3})^2$$

$$\rho = \text{resistivity of aluminium} = 2.8 \times 10^{-8} \text{ } \Omega \text{ m}$$

$$l = 3000 \text{ m}$$

$$R = \frac{(2.8 \times 10^{-8})(3000)}{\pi(9 \times 10^{-3})^2}$$

$$R = 0.33 \text{ } \Omega$$

(iii) Calculate how much electrical energy is converted to heat energy in the wire in ten minutes.

$$W = I^2 R t$$

$$W = (250)^2(0.33)(600) = 1.238 \times 10^7 \text{ J}$$

2008 Question 8

(i) What is electromagnetic induction?

Electromagnetic Induction occurs when an emf is induced in a coil due to a changing magnetic flux.

(ii) State the laws of electromagnetic induction.

Faraday's Law states that the size of the induced emf is proportional to the rate of change of flux.

Lenz's Law states that the direction of the induced emf is always such as to oppose the change producing it.

(iii) Explain why the amplitude of the swings decreases rapidly.

An emf is induced in the copper because it is experiencing a changing magnetic flux.

This results in a current.

This current has a magnetic field associated with it which opposes the motion of the magnet.

(iv) What is the main energy conversion that takes place as the magnet slows down?

Kinetic (or potential) to electrical (or heat).

(v) How long does it take the loop to completely enter the field?

{A diagram helps to visualise what's happening here.}

$$\text{time} = \frac{\text{distance}}{\text{speed}} = \frac{.05}{5} = 0.01 \text{ seconds}$$

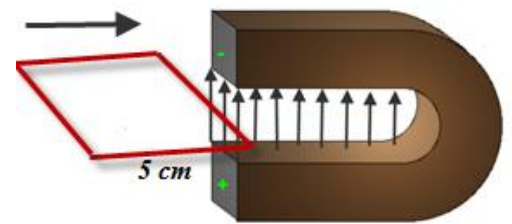

(vi) What is the magnetic flux cutting the loop when it is completely in the magnetic field?

$$\Phi = BA = (8)(0.05)^2 = 0.02 \text{ webers}$$

{the area in this case corresponds to the area of the loop, which is a square of side 0.05 m}

(vii) What is the average emf induced in the loop as it enters the magnetic field?

{The area the flux lines are passing through is 0 when the coil is outside (so magnetic flux is 0).

But when the coil is fully inserted then the flux is a maximum (BA)}

$$\text{Induced emf} = \frac{\text{final flux} - \text{initial flux}}{\text{time taken}} = \frac{0.02 - 0}{0.01} = 2 \text{ Volts}$$

2007 Question 12 (c)

(i) State Faraday's law of electromagnetic induction.

Faraday's Law states that the size of the induced emf is proportional to the rate of change of magnetic flux.

(ii) Describe an experiment to demonstrate Faraday's law.

Move the magnet in and out of the coil slowly and note a slight deflection in the galvanometer.

Move the magnet quickly and note a greater deflection.

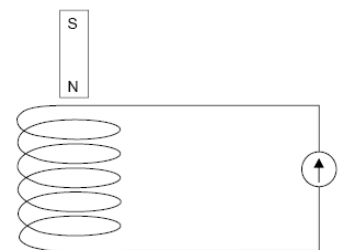

(iii) What is the effect on the current flowing in the circuit?

Current is reduced

(iv) Justify your answer

An emf is induced in coil. This induced emf (known as back emf) has an associated current which opposes the initial current (from Lenz's law).

2006 Question 11

(i) How does resonance occur in an acoustic guitar?

Energy is transferred from the strings to the hollow body and both vibrate at the same frequency.

(j) What is the relationship between frequency and tension for a stretched string?

Frequency is proportional to the square root of tension. $f \propto \sqrt{T}$

(k) A stretched string of length 80 cm has a fundamental frequency of vibration of 400 Hz.

What is the speed of the sound wave in the stretched string?

For a standing wave the length of the wave from node to node corresponds to half the wavelength.

$$\begin{array}{llll}
 l = \frac{\lambda}{2} & \lambda = 2l & \lambda = 2(0.8) & \lambda = 1.6 \text{ m} \\
 v = f\lambda & \Rightarrow & v = 400(1.6) & v = 640 \text{ m s}^{-1}
 \end{array}$$

(l) Why must the strings in the electric guitar be made of steel?

{The permanent magnet under the guitar string causes the guitar string itself to become a low strength magnet. When the string is plucked it now acts like a moving magnet and it is this moving magnet that induces the emf in the coil underneath.

Because only metal strings can be magnetised, it follows that the strings in an electric guitar must be made of steel.}

Answer: Only metal strings can be magnetised

(m) Define magnetic flux.

Magnetic flux is the product of magnetic flux density and area. $\Phi = BA$

(n) Why does the current produced in a coil of the electric guitar vary?

Because the size of the induced emf is proportional to the rate of change of flux, and this in turn is determined by the speed at which the guitar string is moving.

{The speed varies with the amplitude of the string (plucking it harder pulls the string back more).}

(o) What is the effect on the sound produced when the number of turns in a coil is increased?

A louder sound is produced.

(p) What is the emf induced in the coil when the magnetic flux cutting the coil changes by 8×10^{-4} Wb in 0.1 s?

$$\text{Induced emf} = - (N) \left[\frac{\text{final flux} - \text{initial flux}}{\text{time taken}} \right] \qquad \text{Induced emf} = - (5000) \left[\frac{8 \times 10^{-4}}{0.1} \right] = 40 \text{ V}$$

2005 Question 12 (b)

(i) Define magnetic flux.

Magnetic flux is defined as the product of magnetic flux density and area.

(ii) State Faraday's law of electromagnetic induction.

The size of the induced emf is proportional to the rate of change of magnetic flux.

(iii) A square coil of side 5 cm lies perpendicular to a magnetic field of flux density 4.0 T. The coil consists of 200 turns of wire. What is the magnetic flux cutting the coil?

$$A = (0.05)^2 = 0.0025$$

$$\Phi = BA = (4)(0.0025) = 0.01 \text{ Wb}$$

(iv) Calculate the magnitude of the average e.m.f. induced in the coil while it is being rotated.

{this diagram wasn't in the original question but it might be useful to get a picture of what's happening.

When the red coil is vertical there are no magnetic flux lines passing through the coil (the area is 0). But when the coil is horizontal as shown then the magnetic flux is a maximum because the area is a maximum (flux = BA)}

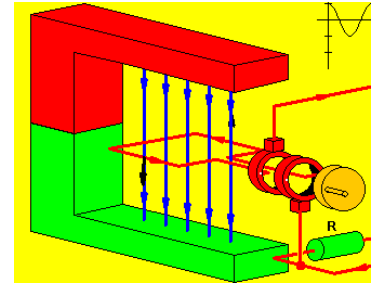

$$\text{Induced emf} = (N) \left[\frac{\text{final flux} - \text{initial flux}}{\text{time taken}} \right]$$

$$E = (200) \left[\frac{0.01 - 0}{0.2} \right] \quad E = 10 \text{ V}$$

2004 Question 12 (c)

(i) What is electromagnetic induction?

Electromagnetic induction occurs when an emf is induced in a coil due to a changing magnetic flux.

(ii) Describe an experiment to demonstrate electromagnetic induction.

Set up as shown.

Move the magnet in and out of the coil and note the deflection in the galvanometer.

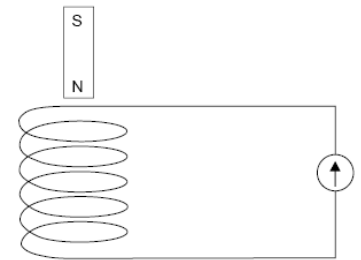

(iii) When a strong magnet is moved away from it, the ring follows the magnet.

Explain why.

An emf is induced in the ring due to the motion of the magnet. This in turn induces a current in the ring which has a magnetic field associated with it.

The direction of the induced magnetic field is such as to oppose the change which caused it. Therefore the side of the ring facing the north pole of the magnet becomes a *south* pole and the ring and magnet attract each other, so the ring follows the magnet.

(iv) What would happen if the magnet were moved towards the ring?

An emf is induced in the ring due to the motion of the magnet. This in turn induces a current in the ring which has a magnetic field associated with it.

*The direction of the induced magnetic field is such as to oppose the change which caused it. Therefore the side of the ring facing the north pole of the magnet becomes a **north** pole and the ring and the magnet repel each other.*

Answer:

The ring would be repelled.

2003 Question 12 (d)

(i) State the laws of electromagnetic induction.

Faraday's law states that the *size* of the induced emf is proportional to the rate of change of flux.

Lenz's Law states that the *direction* of the induced emf is always such as to oppose the change producing it.

(ii) Describe the current flowing in the circuit.

Alternating current.

(iii) If the switch at A is open, the magnet will take longer to come to rest. Explain why.

There is no longer a full circuit, so even though there is an induced emf (potential difference) there is no (induced) current, therefore no induced magnetic field in the coil therefore no opposing force.

2002 Question 12 (c)

(i) What is meant by electromagnetic induction?

Electromagnetic Induction occurs when an emf is induced in a coil due to a changing magnetic flux.

(ii) State Lenz's law of electromagnetic induction.

Lenz's Law states that the direction of the induced emf is always such as to oppose the change producing it.

(iii) Explain why the current was reduced when an iron core was inserted in the coil.

There would normally be a back emf in the coil due to the fact that source voltage is alternating.

When the core was inserted it increased the magnetic flux which in turn increased the self-induction (back emf) and this reduced the overall voltage and therefore the overall current.

(iv) Give an application of the principle shown by this experiment.

Dimmer switch